



The Path to 4G: LTE and LTE-Advanced



James Seymour
Senior Director
Alcatel-Lucent



4G Technology Roadmap - Hosted by 4G Americas

Alcatel-Lucent 

Applications & Devices Driving Bandwidth

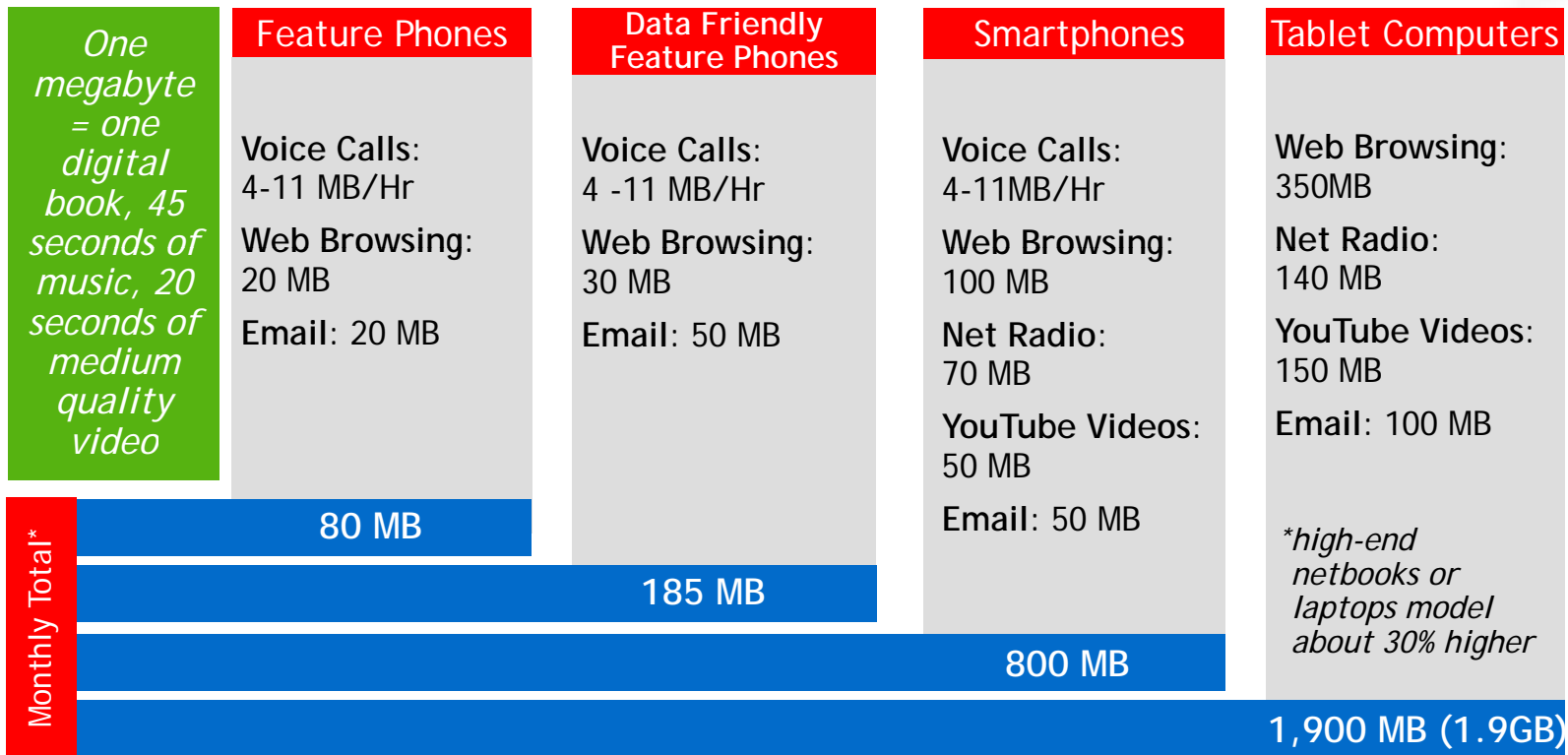

* Estimated

Source: BusinessWeek (February 2010), Data: Internal Alcatel-Lucent Research



4G Technology Roadmap - Hosted by 4G Americas

Alcatel-Lucent 

Smartphone User Profile for 4G



MBps/month/user

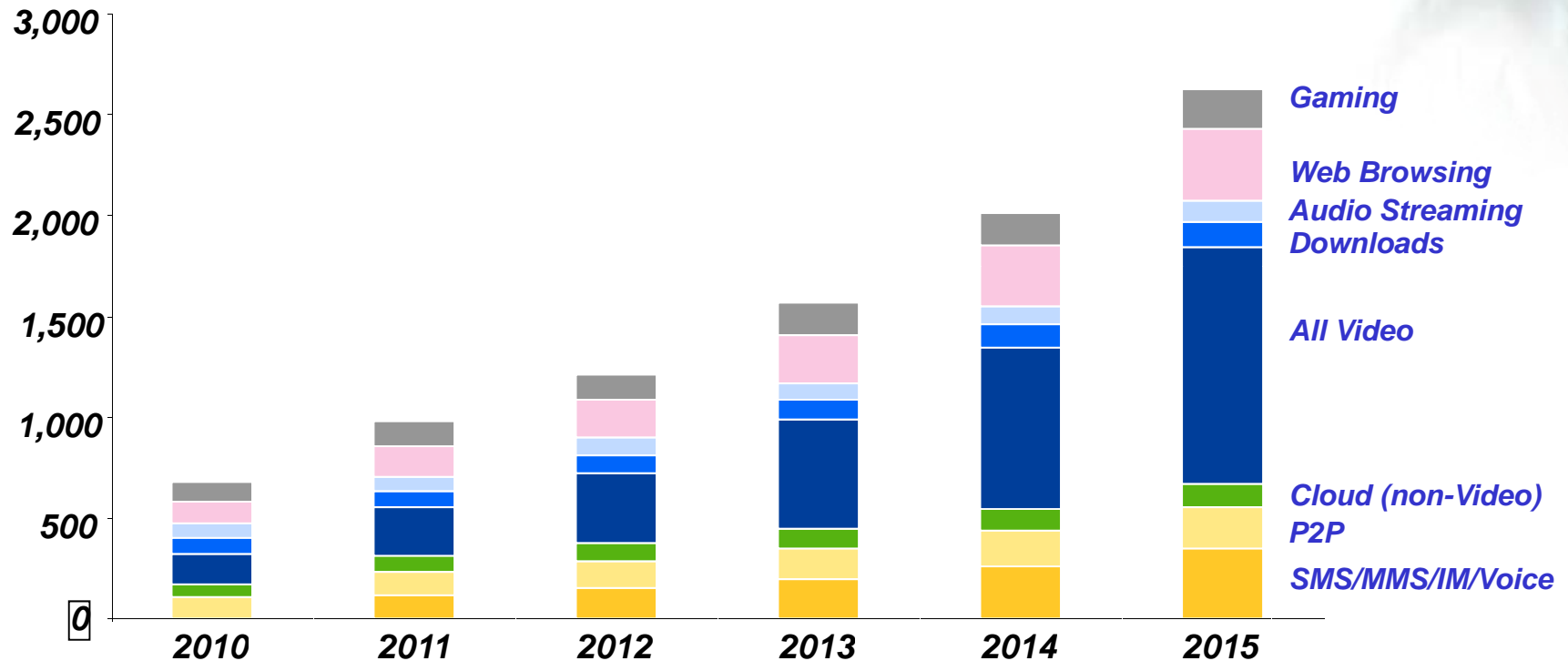

*High Growth in Web, Streaming, Interactive Video Apps
Data Usage per LTE user projected to grow from 700MB to 2.5GB*



4G Technology Roadmap - Hosted by 4G Americas



Meeting the Fast Growing Wireless Data Capacity and User Experience Demands

Broadband Capacity

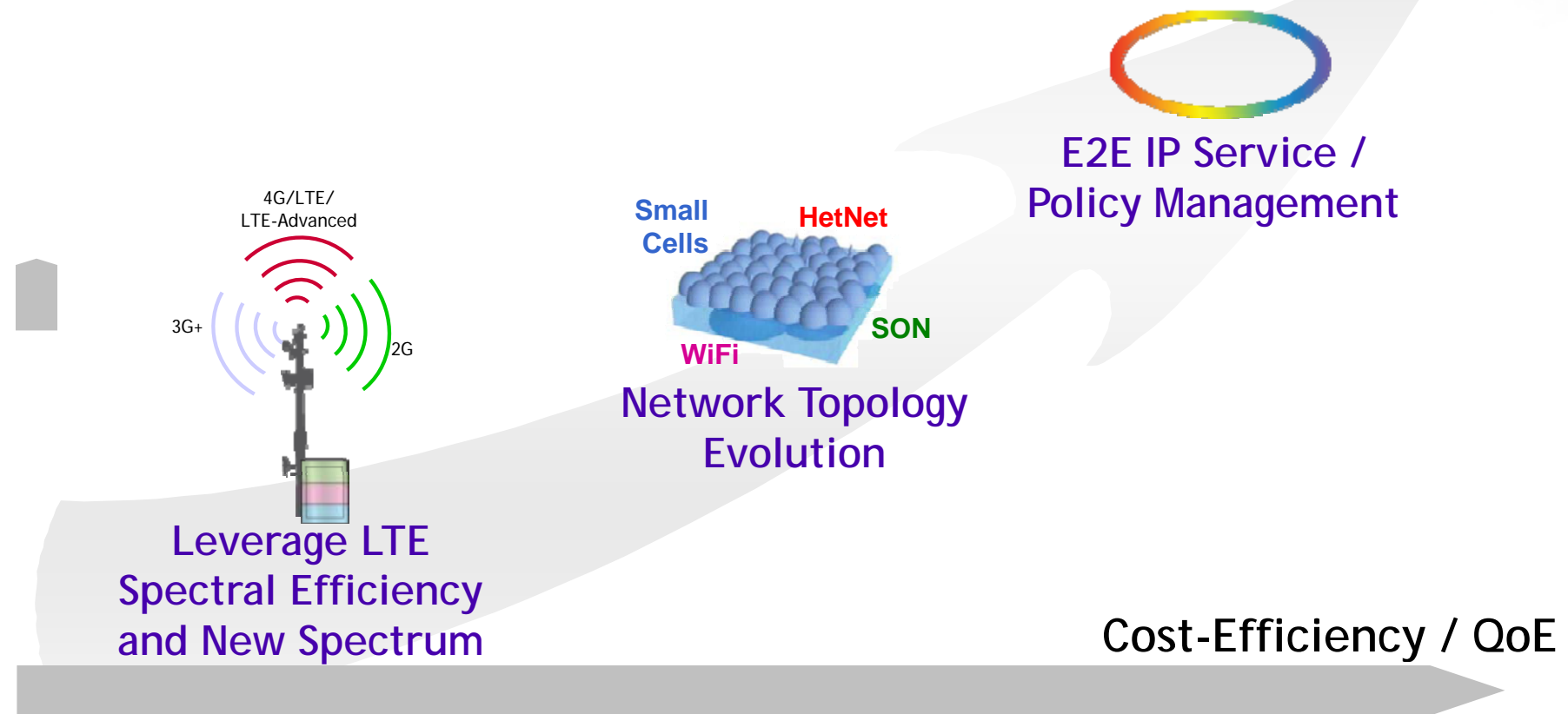

Achieving the End-to-End Solution

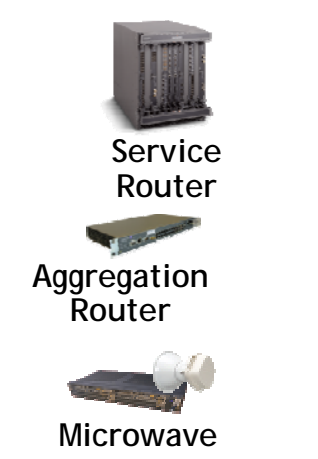
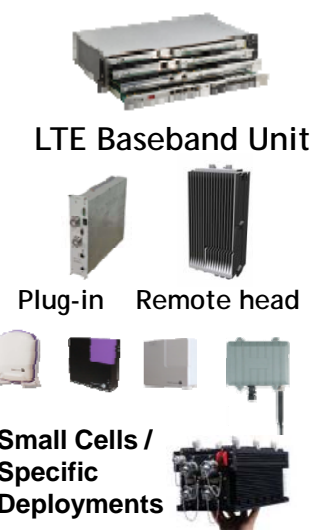
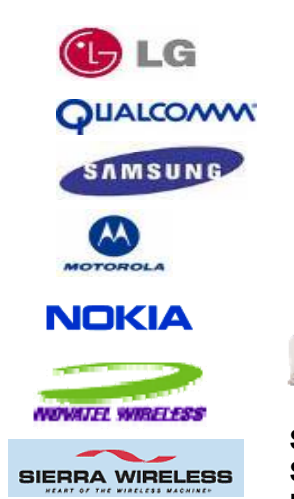
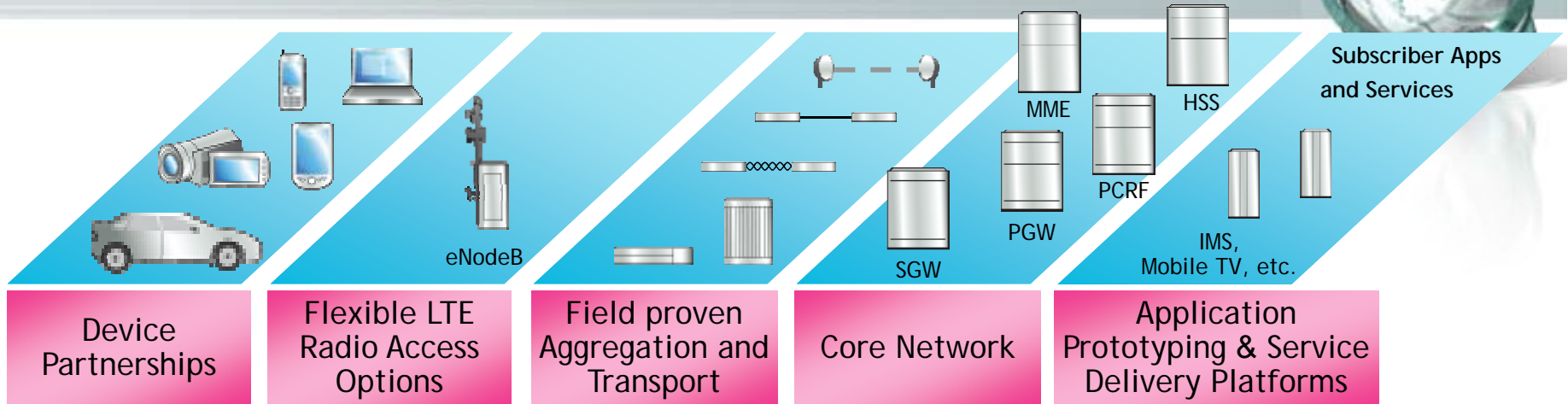

Alcatel-Lucent is paving the way to new wireless business models.



4G Technology Roadmap - Hosted by 4G Americas



Carrier Aggregation (CA) for LTE-Advanced



Carrier Aggregation combines multiple LTE carriers

Intra-band example: 40 MHz

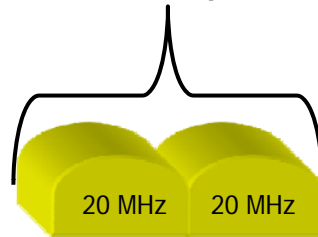

Carrier Aggregation combinations defined as non-release specific.

Inter-band example: 40 MHz

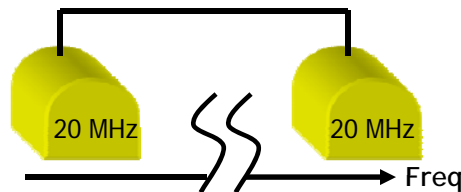

CA Critical for meeting ITU IMT-Advanced Peak Rate Requirement (1 Gbps)

MIMO Enhancements for LTE-Advanced



SM = Spatial Multiplexing
 RI = Rank Indication
 CQI = Channel Quality Indication
 PMI = Pre-coding Matrix Indication
 RS = Reference Symbol

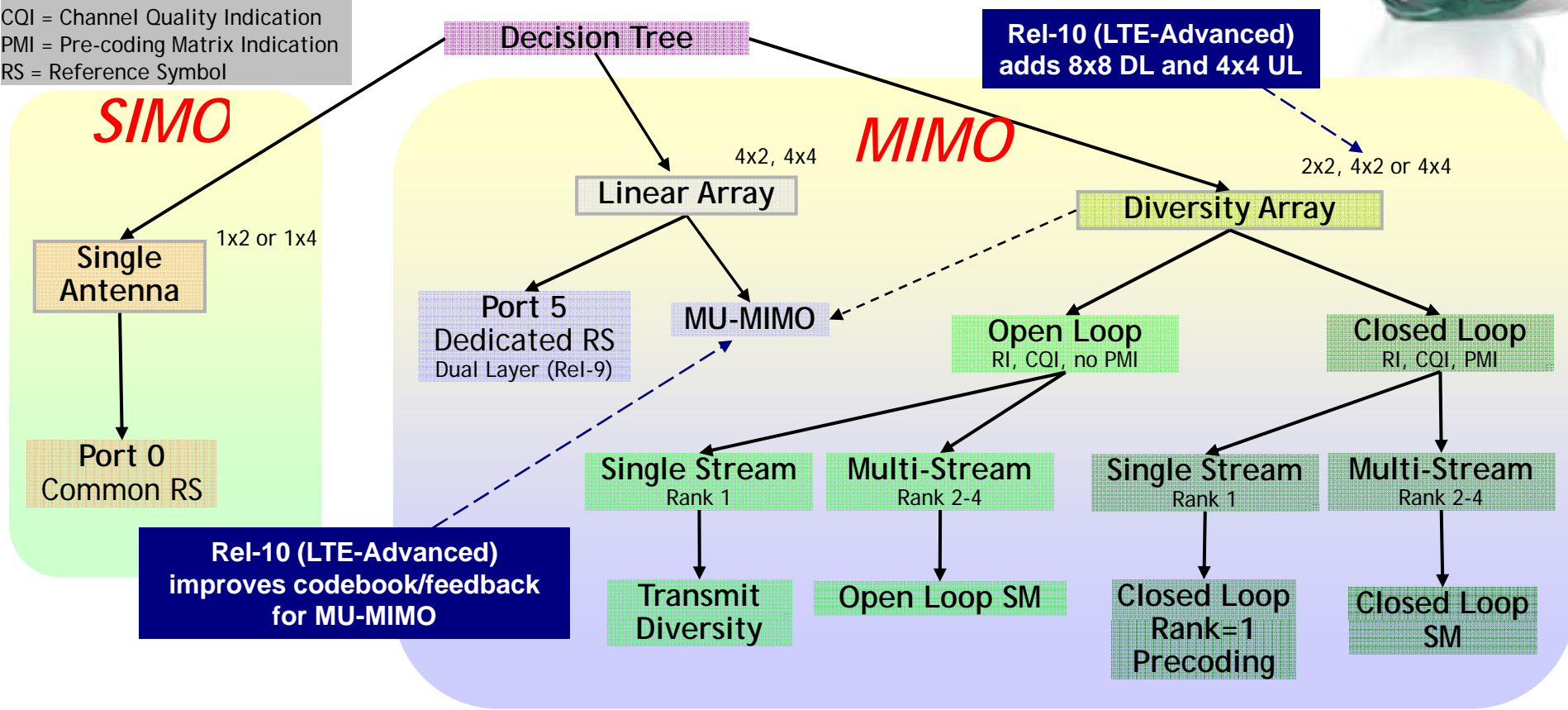

LTE-Advanced builds off the wide range of Rel-8/Rel-9 MIMO capabilities to improve peak rates and spectral efficiency



4G Technology Roadmap - Hosted by 4G Americas



MU-MIMO Enhancement for LTE-Advanced



- MU-MIMO enhancements provide **up to 50% spectral efficiency gain**
- Dynamic switching between SU- and MU-MIMO supported
- Up to 2 layers per UE in MU-MIMO
- Enhanced CSI feedback structure and codebook design

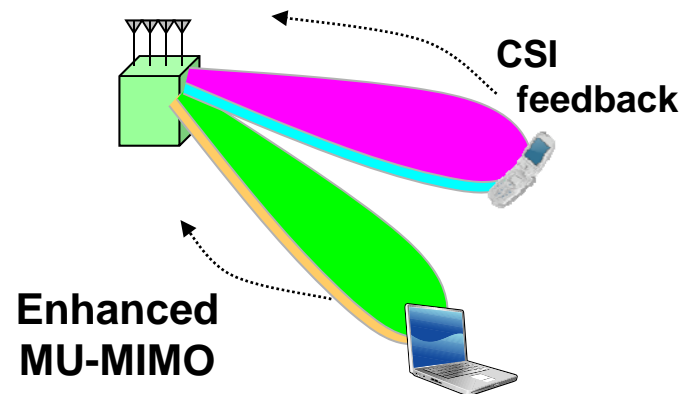

MU-MIMO Enhancements critical for meeting IMT-Advanced DL spectral efficiency requirements

Co-ordinated Multi-Point (CoMP) Multiple Approaches



Interference Avoidance

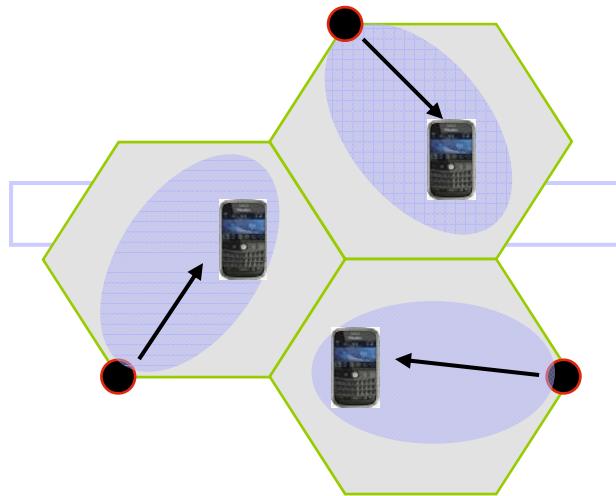

Network MIMO

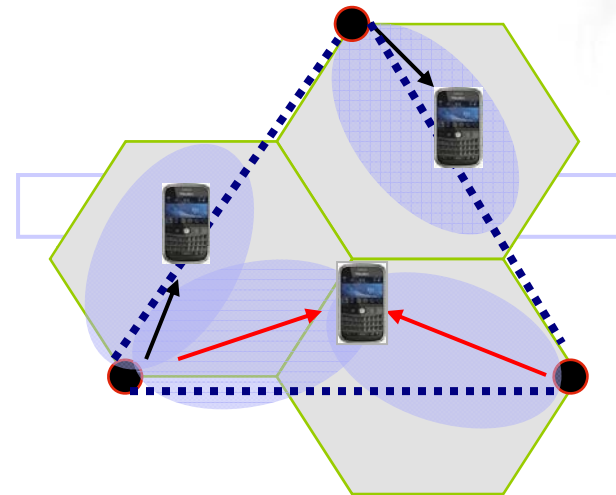

Potential 2x spectral efficiency gain 😊, but complex ☹️

*Advanced forms of CoMP only provide ~2X spectral efficiency increase
still need more cells to meet faster growing wireless data capacity demands* →

Where Small Cells Provide Gains

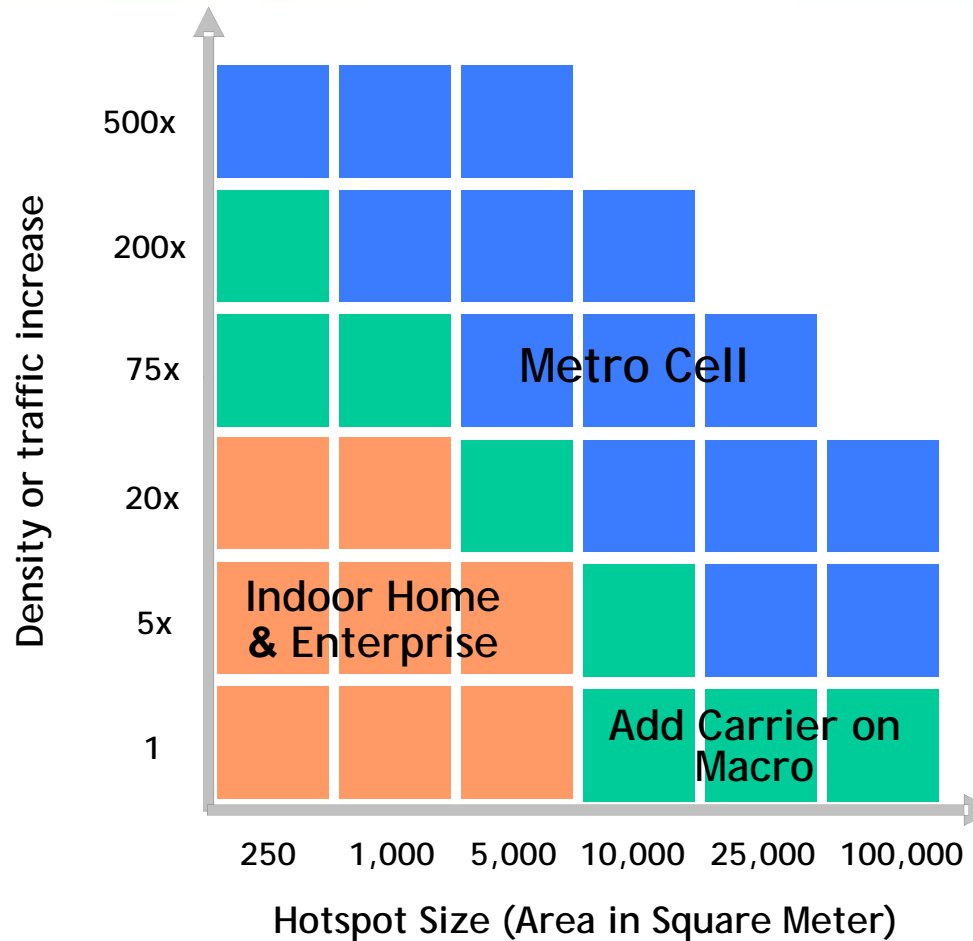

Source: Bell Labs Modeling analysis

Home, Enterprise and Metro Cells compliment the Macro Network



4G Technology Roadmap - Hosted by 4G Americas

Alcatel-Lucent

Interference Management with Small Cells



Frequency Selective Scheduling (FSS), Power Control (PC) and Inter-Cell Interference Coordination (ICIC) enables same carrier HetNet deployments for LTE

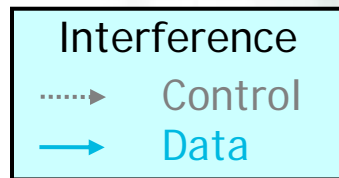
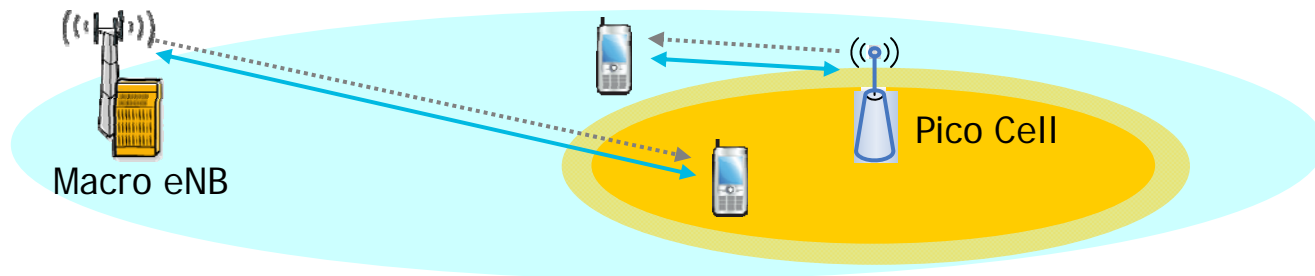

LTE Rel-8 capabilities such can manage LTE HetNet interference.

LTE-Advanced features such as Carrier Aggregation (CA) and Enhanced ICIC (eICIC) will further improve same carrier HetNet performance for LTE

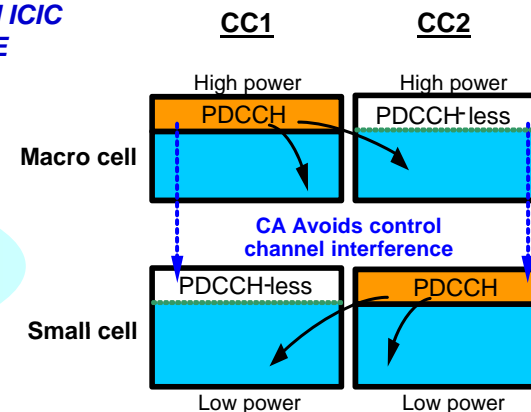
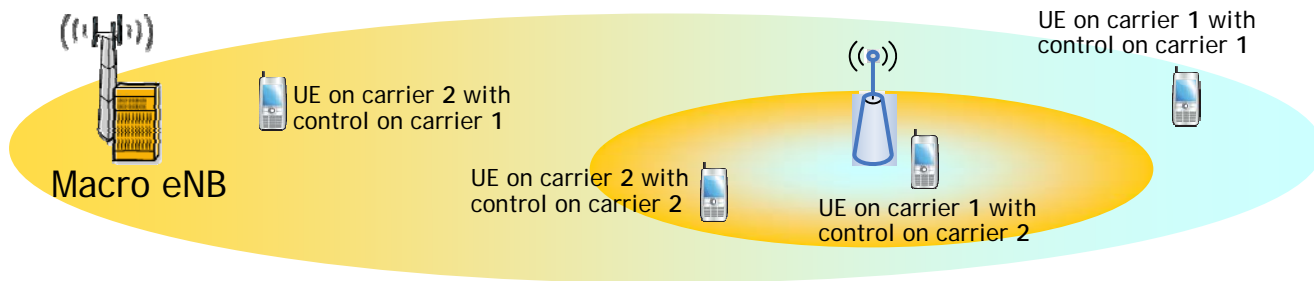

LTE-Advanced techniques further help to manage control channel Interference.



LTE Small Cells/HetNets Performance



Source: Bell Labs Research

3GPP Case I with Configuration 4a

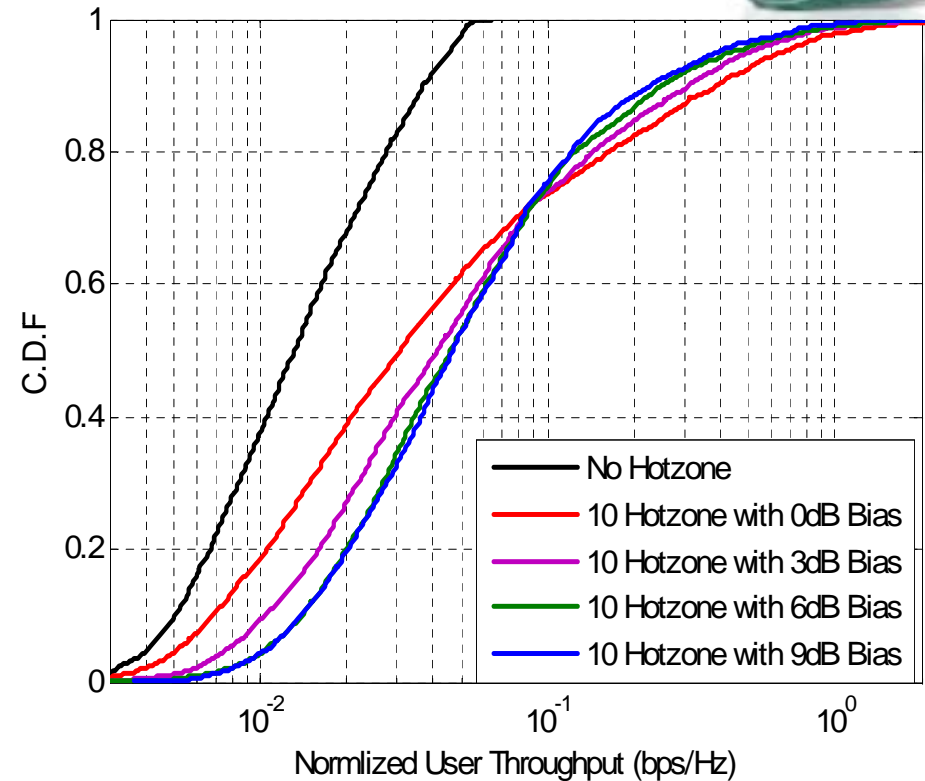
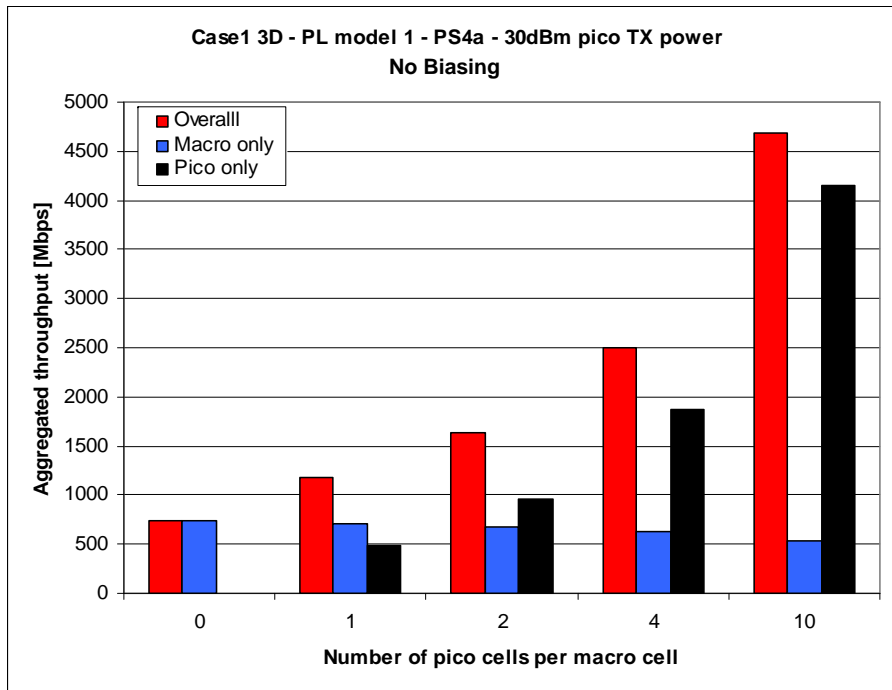

Key Assumptions: Macro: Outdoor RRH based on 3GPP Case1 (ISD = 500m, 2 GHz, 46 dBm),

Small Cell: 30 dBm, 4a dropping criteria → 60 UEs and constant number of small cells per macro; 2 UEs in 40m radius around each small cell; small cells and remaining UEs uniformly distributed,

LTE Small Cell/HetNets provide significant capacity improvement critical for addressing the fast growing wireless data demands



4G Technology Roadmap - Hosted by 4G Americas



Relays



Type I (in band)

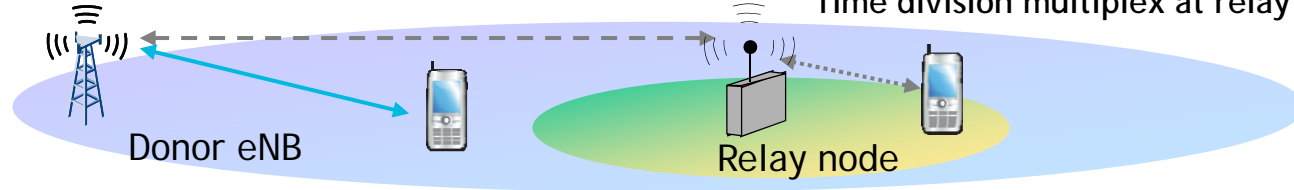

Type Ia (out-of-band providing RF isolation)

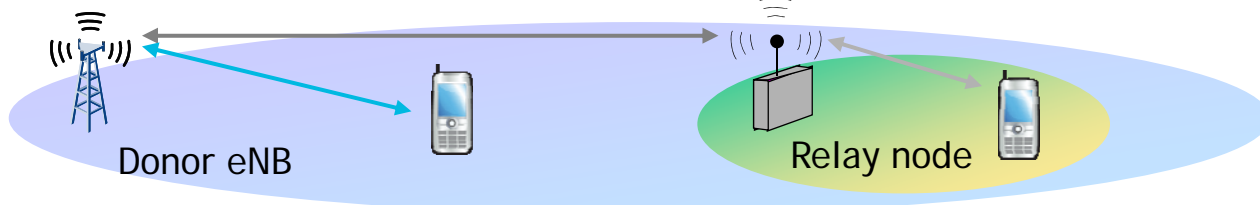

Type Ib (in band, RF isolation)

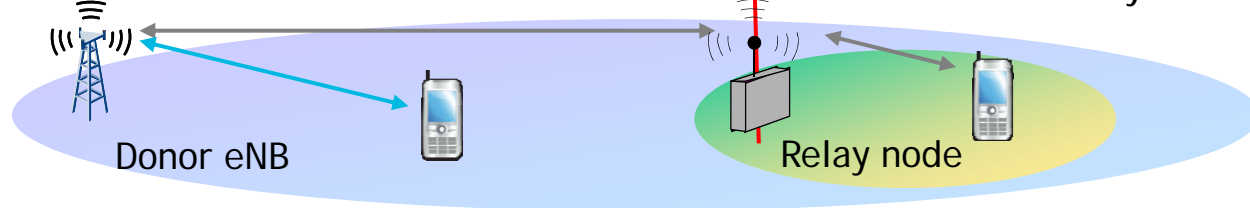

Relays can provide backhaul solution where dedicated backhaul is challenging

Self Optimizing Network (SON)

Innovations to continue through LTE-Advanced



Plug & play femto

Automated neighbor cell relation

Inter-Cell Interference Cancellation based on inter-cell negotiation

- Reduces Hand Over failure
- Improves throughput/QoE
- Performance increase in call set up

Comprehensive SON solution, powered by our 3G experience and Bell Labs Research



4G Technology Roadmap - Hosted by 4G Americas



Summary



- **Fast growing wireless data capacity demands due to smartphones and high growth in web, streaming and interactive video apps**
- **LTE & LTE-Advanced coupled with small cells & relays will address these fast growing wireless data capacity demands**
- **Carrier Aggregation and MU-MIMO enhancements are the key LTE-Advanced features for meeting IMT-Advanced requirements**
 - CoMP has potential to provide significant further spectral efficiency gain with added complexity
 - Relays and continued SON evolution to support E2E and HetNet optimizations are additional LTE-Advanced features
- **Alcatel-Lucent is delivering market leading end-to-end LTE solution with smooth evolution to LTE-Advanced, paving the way to new business models**